



25-GALLON DIESEL CADDY USER'S MANUAL

FOR WARRANTY INFORMATION, PLEASE CALL 800-433-0708

MODEL NO: _____

DATE OF PURCHASE: _____

READ AND SAVE THIS MANUAL

FOR SERVICE ASSISTANCE, CALL 800-433-0708 OR VISIT JOHNDOW.COM



Important Safety Information

Read user's manual and this safety information before using this product.

DANGER

DANGER indicates a hazardous situation which, if not avoided, will result in death or serious injury.

The use of this product includes the handling of diesel.

DANGER DIESEL
COMBUSTIBLE
HARMFUL OR FATAL IF SWALLOWED
DO NOT USE THIS CONTAINER FOR
GASOLINE OR OTHER FLAMMABLE
LIQUIDS

- Keep out of reach of children.
- Avoid prolonged breathing of vapors.
- Do not siphon by mouth.
- Do not store in vehicle or living space.
- Store and use in well-ventilated area.
- Do not use near heat, spark, or flame.
- Keep container closed.
- Do not smoke near or while using this product.

WARNING

WARNING indicates a hazardous situation which, if not avoided, could result in death or serious injury.

Static charge and container filling warnings.

- Lay tank in horizontal position on the ground (valve and fill cap facing up) when filling.
- Do not fill while on trailer or truck bed.
- Dissipate any static electricity from your body by touching a metal surface away from the service station nozzle and prior to removing service station nozzle from dispensing pump.
- Keep service station nozzle in contact with tank while filling.
- Do not use service station nozzle lock-open device while filling.
- Do not re-enter vehicle while filling. Re-entry can cause static buildup on person and create spark.
- Fill slowly to prevent buildup of static charge.
- Do not use electronics or mobile phones while using this product.
- Do not use funnels to fill or dispense fuel with this product.
- If fire starts, do not remove service station nozzle. Back away immediately.

WARNING

WARNING indicates a hazardous situation which, if not avoided, could result in death or serious injury.

Use, transportation, and storage warnings.

- Confirm all users are trained on safe working practices and comply with any and all regulations for using, transporting, and storing diesel.
- Confirm all fittings and connections are tight and leak-free.
- Do not modify this product or its components.
- Use only diesel in this diesel caddy to avoid possible damage to equipment.
- Perform the entire closure procedure after filling and before transporting.
- Do not place inside a vehicle trunk or inside passenger cabin.
- Secure or strap diesel caddy to a trailer or truck bed with appropriate working load ratchet-style polyester cargo tie-down straps.
- Do not store in direct sunlight.
- Open fill cap manual vent screw slowly to release internal pressure prior to opening valve and nozzle.
- Use care when maneuvering to prevent injury or loss of control. Seek assistance to avoid strain or injury.
- State and local regulations vary for the transportation of diesel. It is the vehicle operator's responsibility to review and comply with all federal, state, and local regulations regarding diesel transportation.
- It is the owner's/user's responsibility to review and comply with all building and fire codes regarding proper storage of diesel.
- Do not attach restraining devices to the ball valve, hose fittings, or fill cap.

REGULATIONS FOR USE

The persons or functions using this product may be subject to additional regulations including PHMSA, DOT 49 CFR Subchapter C – Hazardous Materials Regulations (HMR) as well as requirements of other federal agencies, and requirements of state and local government agencies. It is the persons responsibility to determine the applicability of these regulations and for compliance to these regulations.

Resources for additional information

<https://www.phmsa.dot.gov/regulations-and-compliance>

<https://www.phmsa.dot.gov/about-phmsa/phmsa-faqs>

GETTING STARTED

Before assembly, ensure you have all parts according to the contents list below. If any parts are missing or damaged, contact JohnDow Industries for replacement.

CONTENTS

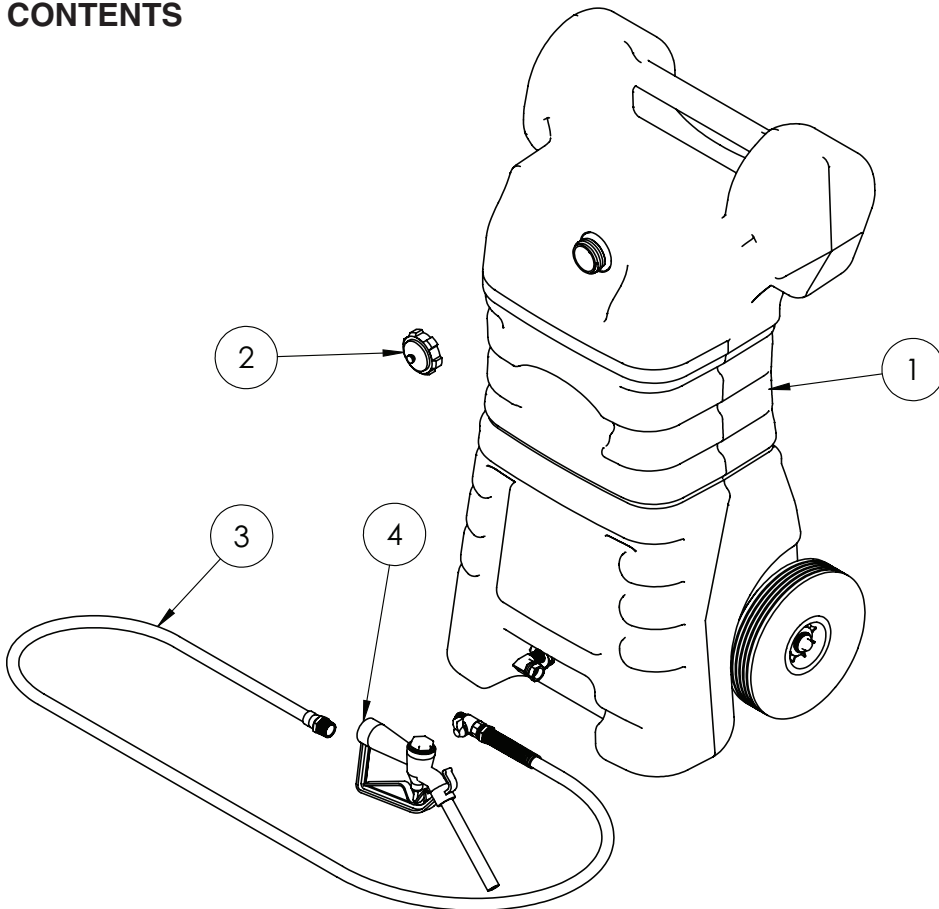

Item No.	Description	Qty.
1	Blow Molded 15- / 25-gallon Fuel Caddy Tank	1
2	2-1/4" Fill Cap w/Rubber Gasket	1
3	1/2" x 8' Hose w/ 1/2" NPT & 3/4" NPT Fittings	1
4	Dispensing Nozzle	1

ASSEMBLY INSTRUCTIONS

1. Assemble the ½” threaded fitting of the hose [3] into the valve on the bottom of tank [1]. Refer to “A” of Figure 1. Do not use any pipe sealant or tape on this connection.
2. Assemble dispensing nozzle [4] onto fitting and tighten. Refer to “B” of Figure 1.
3. Confirm fill cap [2] is on tank prior to use.
4. Check if pneumatic tires need inflation. If so, inflate to 15 psi prior to use.

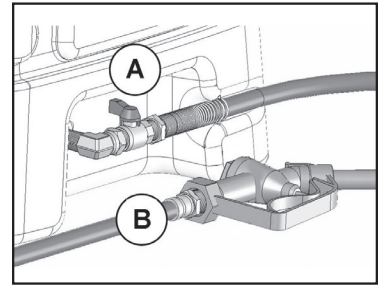

Figure 1

TO FILL DIESEL CADDY

Before filling, read and follow all safety instructions on page 2 of this user's manual.

1. Always lay diesel caddy on the ground in horizontal position (valve and fill cap facing up) away from vehicle before filling to dissipate any static charge.
2. Dissipate any static electricity from your body by touching a metal surface away from the service station nozzle and prior to removing service station nozzle from dispensing pump.
3. Ensure the ball valve is closed. The ball valve handle should be in a 90° position to the valve body, as described in 'To Close and Secure for Transportation and Storage'.
4. Remove fill cap from diesel caddy and insert service station nozzle into the filler neck opening.
5. While filling:
 - a. Do not remove service station nozzle from diesel caddy. Keep the service station nozzle in contact with the rim of the diesel caddy at all times until fueling is complete.
 - b. Do not use service station nozzle lock-open device. Fill slowly to prevent the buildup of static charge. Stop immediately if you sense the buildup of static charge. Do not resume filling until static charge dissipates.
 - c. Closely monitor flow to prevent spills and overfilling. Do not fill above the bottom of the filler neck.
6. Replace fill cap and tighten as securely as possible by hand.
7. Wipe any diesel residue from surface of diesel caddy or allow to evaporate. If fuel spills on clothing, change clothing immediately.

TO DISPENSE FUEL FROM DIESEL CADDY

Before filling, read and follow all safety instructions on page 2 of this user's manual.

1. Position diesel caddy in upright, vertical position.
2. Slowly twist open fill cap's manual vent screw to release any internal pressure.
3. Open valve by turning the ball valve handle clockwise. The ball valve handle should be parallel with the valve body as shown in Figure 2.
4. Insert nozzle into equipment needing fuel.
5. Fuel is gravity-dispensed through nozzle. Squeeze handle to begin flow, release to stop. Do not remove the nozzle while dispensing and monitor flow and liquid level to prevent spills.
6. When finished, drain remaining fuel back into the tank per the procedure below.

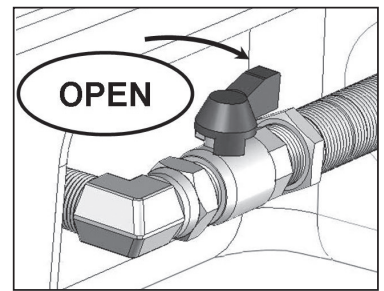

Figure 2

TO DRAIN FUEL FROM HOSE BACK INTO DIESEL CADDY

Before filling, read and follow all safety instructions on page 2 of this user's manual.

1. Lay diesel caddy in horizontal position (valve and fill cap facing up).
2. Elevate the nozzle above the hose and slope the hose back to the valve providing a clear path for fluid to drain.
3. Squeeze the handle of the nozzle to allow the hose to vent and fuel to drain back into the tank.
4. Close the ball valve per the procedure below.

TO CLOSE AND SECURE FOR TRANSPORTATION OR STORAGE

Before transporting and storage, read and follow all safety instructions on page 2 of this user's manual.

1. Return all fuel from hose back into tank per above instructions.
2. To close the diesel caddy:
 - a. Close ball valve by turning the handle counterclockwise until it stops in 90° position as shown in Figure 3.
 - b. Replace fill cap and tighten in the clockwise direction as securely as possible by hand, as shown in Figure 4.
 - c. Tighten fill cap's manual vent screw in the clockwise direction as securely as possible by hand, as shown in Figure 4.

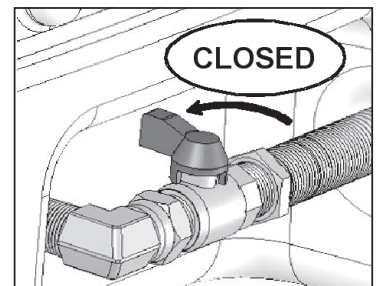

Figure 3

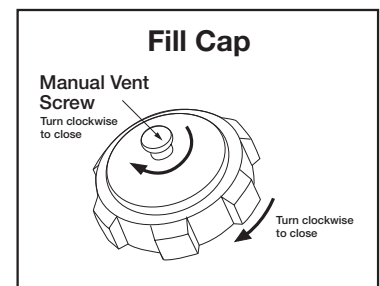

Figure 4

TO LOAD FOR TRANSPORTATION

Before transporting and storage, read and follow all safety instructions on page 2 of this user's manual.

1. Load diesel caddy onto a trailer or truck bed and place in horizontal position (valve and fill cap facing up).
2. Secure the diesel caddy with proper restraining devices, like ratchet-style polyester cargo tie-down straps having a 300 lb. minimum working load (WL), to prevent movement in all directions. The restraining devices can contact the fuel caddy tank in the grooved ribs, around the molded handle, or around the axle. Do not attach restraining devices to the ball valve, hose fittings, or fill cap.

STORAGE

Before storing, read and follow all safety instructions on Page 2 of this user's manual.

Upon use, all statements below apply, whether the diesel caddy is empty, full, or partially full.

Store diesel caddy upright after completing closing instructions per above and in accordance with the following:

1. It is the user's responsibility to review and comply with all local and state building and fire codes regarding proper storage of diesel and the approved storage locations.
2. Store in well-ventilated area away from direct sunlight, flame, pilot lights, stoves, heaters, electronic motors and other sources of ignition.
3. Do not store inside a vehicle passenger cabin or trunk, residence, living space or basement, or an attached garage connected to residence or dwelling.

REPLACEMENT PARTS

Part No.	Description
BV-1/2NPTMF	1/2" NPT MxF Ball Valve
201594	2-1/4" Fill Cap w/Rubber Gasket
80-593-14	1/2" x 8' Hose w/1/2" NPT & 3/4" NPT Fittings
JL-5116-1	Dispensing Nozzle
P1030-20P-R	10" Pneumatic Wheel
14174	5/8" Cap Washer

PRODUCTION TESTING AND REUSE

This model DOT approved packaging for the transport of UN 1202 / UN 1993, Diesel, Packing Group II and was leak proofness tested per 49 CFR §178.604 during production.

However, in order to assure the integrity and performance of the packaging 49 CFR §178.604 also requires production testing prior to reuse per 49 CFR §173.28. For this model, the requirement to retest before reuse begins 5 years after the date of manufacturer marked on the product. The certification marking contains a 2- digit year code. The month is indicated on an adjacent date code wheel molded in the body. The product may be reused without retesting for 5 years beyond the marked date.

